

## V. ITEMS FOR DISCUSSION

- a. Approve the United Concordia Dental Change from Advantage to Elite Prime at an estimated annual cost of \$8,476.00 (or \$1.07 per employee per month)

**Dental Benefits Summary for East Stroudsburg Area School District**  
254025000, 001, 002

Effective Date: January 1, 2024

**New Enhanced Network: *Elite Prime***

Benefit Category <sup>1</sup>	CONCORDIA FLEX PLAN	
	In-Network <sup>2</sup>	Non-Network <sup>2,3</sup>
<b>Class I – Diagnostic/Preventive Services</b>		
Exams	100%	100%
Bitewing X-rays		
All Other X-rays		
Cleanings & Fluoride Treatments		
Sealants		
Space Maintainers		
Palliative Treatment		
<b>Class II – Basic Services</b>		
Basic Restorative (Fillings)	100%	100%
Simple Extractions		
Repairs of Crowns, Inlays and Onlays		
Endodontics		
Inlays, Onlays, Crowns		
Complex Oral Surgery		
General Anesthesia		
<b>Class III – Major Services</b>		
Nonsurgical Periodontics	50%	50%
Surgical Periodontics		
<b>Orthodontics (To Any Age)</b>		
Diagnostic, Active, Retention Treatment	50%	50%
<b>Included Plan Features</b>		
The College Tuition Benefit® – College Savings Program <sup>4</sup>	<ul style="list-style-type: none"> <li>• Earn Tuition Rewards® points redeemable for tuition discounts</li> <li>• Receive 2,000 at signup, then 2,000 points/year</li> <li>• Each child enrolled receives a one-time bonus of 500 Tuition Rewards points</li> <li>• One Tuition Rewards point = \$1 reduction in full tuition</li> <li>• Use Tuition Rewards points at participating private colleges and universities</li> </ul>	
<b>Maximums &amp; Deductibles (applies to the combination of services received from network and non-network dentists)</b>		
Calendar Year Program Deductible (per member/per family) (January 1 – December 31)	None	
Calendar Year Program Maximum (per member) (January 1 – December 31)	\$1,250 Excludes Orthodontics	
Lifetime Orthodontic Maximum (per member)	\$1,500	
<b>Reimbursement</b>	<b>Elite Prime</b>	<b>Advantage MAC in PA; 90<sup>th</sup> Percentile outside PA</b>

Representative listing of covered services – your employer's Summary Plan Description provides a detailed description of benefits.

Dental plans are administered by United Concordia Companies, Inc. Administrative and claims offices located at 1800 Center Street Suite 2B 220, Camp Hill, PA 17011. Call 1-800-332-0366 or visit [www.ucci.com](http://www.ucci.com) for more information.

1. Unmarried dependent children covered to age 19. Unmarried dependent students covered to age 23.
2. Reimbursement is based on our schedule of maximum allowable charges (MACs). Network dentists agree to accept our allowances as payment in full for covered services. Non-network dentists may bill the member for any difference between our allowance and their fee (also known as balance billing). United Concordia Dental's standard exclusions and limitations apply.
3. United Concordia creates out-of-network charges utilizing FAIR Health data supplemented with our charge data as appropriate. We then calculate the out-of-network charge at the 90<sup>th</sup> Percentile of such data. Non-network dentists may bill the member for any difference between our allowance and their fee.
4. Tuition Rewards® is a Registered Trademark of and administered by SAGE Scholars, Inc. Participation in the program is contingent upon enrollment with SAGE Scholars, Inc. Tuition Rewards are not an underwritten benefit but a value-added program. Tuition Rewards not available in all jurisdictions (SAGE). SAGE is not a subsidiary or affiliate of United Concordia Companies, Inc. (UCCI). Subject to eligibility requirements and terms and conditions. Tuition Rewards are a value-added program and not an insured benefit. Program participation subject to enrollment with SAGE. "Points" are credits that may be used to discount the cost of Tuition and have no cash value. UCCI does not provide services related to this program. Tuition Rewards not available in all jurisdictions. Program subject to change without notice.

The Plan complies with applicable Federal civil rights laws and does not discriminate on the basis of race, color, national origin, age, disability, or sex.

English	ATTENTION: If you speak English, language assistance services, free of charge, are available to you. Call 1-800-332-0366 (TTY: 711).
Español (Spanish)	ATENCIÓN: Si habla español, le ofrecemos de ayuda lingüística gratuita. Llame al 1-800-332-0366 (TTY: 711).
繁體中文 (Chinese)	注意：如果您使用繁體中文，您可以免費獲得語言援助服務。請致電 1-800-332-0366 (TTY: 711)。

## V. ITEMS FOR DISCUSSION

- b. Approve TranslateLive at a cost of \$29,837.00 (the lowest of 3 quotes received)

# Form 611

marialena-casciotta@esasd.net [Switch account](#)



Your email will be recorded when you submit this form

**\* Indicates required question**

Untitled Section

**FORM 611**

**EAST STROUDSBURG AREA SCHOOL DISTRICT**  
Procurement Form

Name of Requestor \*

Marialena Casciotta

Department \*

Pupil Services



Building \*

Administration

What service or item are requesting \*

Translate Live

Why are you requesting the service or item \*

This product allows our non-english speaking families to fully participate in school activities and/or meetings by having their voice translated in real time into English while our voice is translated into the families primary (1st language).

Suggested replacement \*

There isn't a suggested replacement.



Please complete an independent Cost Analysis. (Pre-determine costs prior to contacting a vendor.)

N/A



Cost Estimate: if over \$5,000, were three (3) quotes obtained? If yes, please list \*  
the vendor's information and quoted amount.





Three quotes were obtained.

Company: Services: Cost:

Company: TranslateLive, LLC

Services:

13 ILA Pro: Dual-Screen purpose-built device (\$28,587.00)

- 1 year limited warranty
- Training/Professional Development/Tech Support
- Free shipping
- AI service for three (3) years

5 Broadcast mode: Broadcast mode (1000 min each) \$1,250.00

Cost: \$29,837.00\*

(\*Total does not include tax, if applicable. \*\*After this initial 3 year period, customer will be invoiced \$480/year per device for AI/ILA service)

Company: VTCSecure

Services:

13 ILA Pro: Dual-Screen purpose-built device (\$32,487.00)

- 1 year limited warranty
- Training/Professional Development/Tech Support
- Free shipping
- AI service for three (3) years

5 Broadcast mode: Broadcast mode (1000 min each) \$1,250.00

Cost: \$33,737.00

Company: Carahsoft Technology Corp

Services:

13 ILA PRO: Dual-Screen purpose-built device (\$32,837.00)

- 3 years of SAAS live conversation
- AI transcription services
- Secure, real-time, back-and-forth conversation in multiple languages

5 Broadcast mode: 1,000 minutes each (\$1,225.00)

- One-way-to-many communication
- Multiple guests can join a Host's room via webpage and pick their preferred language

Cost: \$33,062.00



What is the total cost of the purchase? \*

\$29, 837.00

Procurement Method: \*

- Quote Received only one Proposal
- Request for Proposal (RFP)
- Bid
- Other:

Was this purchase budgeted? \*

No ▼



Was this purchased through a PA State Contract or Approved Consortiums? If yes, select group.

- Yes
- Pennsylvania State Contract
- COSTARS
- Keystone Purchasing Network
- PEPPM National Contract Program (Technology Bidding and Purchasing)
- US Communities
- No

If item was purchased through a Pa State Contract or approved Consortium, please include contract number.

N/A

Which Fund will be charged? \*

Choose ▼



What account will be charged? \*

Your answer

Selection of the winning proposal, was the lowest price selected? If not, please explain why and the process of selecting the vendor. \*

Yes

Any additional information you would like to provide.

This product would allow parents and families the opportunity to participate in meetings and discussions with the district without a language barrier existing.

A copy of your responses will be emailed to [marialena-casciotta@esasd.net](mailto:marialena-casciotta@esasd.net).

[Back](#)

[Submit](#)

[Clear form](#)

Never submit passwords through Google Forms.

This form was created inside of East Stroudsburg Area School District. [Report Abuse](#)



Google Forms





## V. ITEMS FOR DISCUSSION

- c. Approve the revised Senior Rebate Resolution for the 2023 Calendar Year  
(see attached)

**EAST STROUDSBURG AREA SCHOOL DISTRICT  
MONROE AND PIKE COUNTIES, PENNSYLVANIA  
REVISED RESOLUTION OF THE BOARD OF EDUCATION**

A RESOLUTION providing property tax rebates for each calendar year to certain senior citizens, widows, widowers and disabled persons with fixed and limited incomes; establishing uniform standards and qualifications for eligibility to receive a rebate; and providing penalties for fraudulent claims.

WHEREAS, the Board of Education of the East Stroudsburg Area School District recognizes the economic plight of certain senior citizens, widows, widowers and disabled persons with fixed and limited incomes who are faced with rising living costs and increasing tax and inflation cost burdens which threaten their homesteads and self-sufficiency; and

WHEREAS, the Board of Education considers it to be a matter of sound public policy to make special provisions for property tax rebates to that class of senior citizens, widows, widowers and disabled persons who are real property taxpayers and who are without adequate means of support to enable them to remain in peaceable possession of their homes and to relieve their economic burden.

NOW, THEREFORE, the Board of Education of the East Stroudsburg Area School District of Monroe and Pike Counties, Pennsylvania, hereby adopts the following Resolution, to be known as the "Senior Citizens Property Tax Rebate Resolution of 1982, as amended", which adoption is intended to reaffirm the original resolution as passed in 1982, to incorporate herein all subsequent amendments and to amend and clarify certain aspects of the original resolution to conform to current Commonwealth legislation.



## Section 1

### Definitions

The following words and phrases, when used in this Resolution shall have the meanings ascribed to them in this Section, except where the context clearly indicates or requires a different meaning.

1.1 "Income" means all income from whatever source derived, including, but not limited to:

- (1) Salaries, wages, bonuses, commissions, income from self-employment, alimony, support money, cash public assistance and relief.
- (2) The gross amount of any pensions or annuities, including railroad retirement benefits for calendar years prior to 1999 and 50% of railroad retirement benefits for calendar years 1999 and thereafter.
- (3) All benefits received under the Social Security Act (49 Stat. 620, 42 U.S.C. § 301 et seq.), except Medicare benefits, for calendar years prior to 1999, and 50% of all benefits received under the Social Security Act, except Medicare benefits, for calendar years 1999 and thereafter.
- (4) All benefits received under State unemployment insurance laws and veterans' disability payments.
- (5) All interest received from the Federal or any state government or any instrumentality or political subdivision thereof.
- (6) Realized capital gains and rentals.
- (7) Workers' compensation.
- (8) The gross amount of loss of time insurance benefits, life insurance benefits and proceeds, except the first \$5,000 of the total of death benefit payments.
- (9) Gifts of cash or property, other than transfers by gift between members of a household, in excess of a total value of \$300.

The term does not include surplus food or other relief in kind supplied by a governmental agency, property tax or rent rebate or inflation dividend.

1.2 "Household Income" means all income received by a claimant and the claimant's spouse while residing in the homestead during the calendar year for which a rebate is claimed.

1.3 "Homestead" means a dwelling, and so much of the land surrounding it as is reasonably necessary for the use of the dwelling as a home, owned and occupied by a claimant.

The term includes, but is not limited to:

- (1) Premises occupied by reason of ownership in a cooperative housing corporation.
- (2) Mobile homes which are assessed as realty for local property tax purposes and the land, if owned by the claimant, upon which the mobile home is situated, and other similar living accommodations.
- (3) A part of a multidwelling or multipurpose building and a part of the land upon which it is built.
- (4) Premises occupied by reason of the claimant's ownership of a dwelling located on land owned by a nonprofit incorporated association, of which the claimant is a member, if the claimant is required to pay a pro rata share of the property taxes levied against the association's land.
- (5) Premises occupied by a claimant if the claimant is required by law to pay a property tax by reason of the claimant's ownership, including a possessory interest, in the dwelling, the land or both. An owner includes a person in possession under a contract of sale, deed of trust, life estate, joint tenancy or tenancy in common or by reason of statutes of descent and distribution.

1.4 "Real Property Taxes" means all taxes on a homestead (exclusive of municipal assessments, delinquent charges, and interest) levied or imposed by the East Stroudsburg Area School District and due and payable during a calendar year.

1.5 "Claimant" means a person who files a claim for property tax rebate and:

- (1) was at least 65 years of age or whose spouse, if a member of the household, was at least 65 years of age during a calendar year in which real property taxes or rent were due and payable;
- (2) was a widow or widower and was at least 50 years of age during a calendar year or part thereof in which real property taxes were due and payable; or
- (3) was a permanently disabled person 18 years of age or older during a calendar year or part thereof in which the real property taxes were due and payable.

## Section 2

### Property Tax Rebate

2.1 Any claim for a property tax rebate for real property taxes paid to the East Stroudsburg Area School District shall for any calendar year be limited to the excess of real property taxes paid to the District over the real property tax rebate available by reason of the payment of such school taxes under the Senior Citizens Property Tax and Rent Rebate Assistance Program of the Commonwealth of Pennsylvania. Claimants must make a claim under the Senior

Citizens Property Tax and Rent Rebate Assistance Program of the Commonwealth of Pennsylvania prior to making a claim with the East Stroudsburg Area School District. Rent or inflation rebates shall not be considered by the District. The amount of such claim under this Resolution for the 2019 tax year and subsequent tax years shall be determined in accordance with the following schedule unless otherwise adjusted by the Board of Education:

<u>Household Income:</u>	<u>Allowed as Rebate (over amount of PA rebate available)</u>
\$0 - \$ 8,000 .....	<del>\$.650</del> \$1,000
8,001 - 15,000.....	<del>\$.500</del> \$770
15,001 - 18,000.....	<del>\$.300</del> \$460
18,001 - <del>35,000</del> -\$45000.....	<del>\$.250</del> -\$380
Over <del>\$35,000</del> -\$45000.....	\$.0

2.2 The maximum amount of rebate payable under this Resolution shall not exceed ~~Six Hundred Fifty~~ One Thousand Dollars (~~(\$650.00)~~(\$1,000)) per calendar year, subject to increase as set forth in Section 2.3, below.

2.3 The “Allowed as Rebate” figures set forth in the table at Section 2.1, above, shall increase annually in accordance with increases in the Commonwealth’s Senior Citizens Property Tax and Rent Rebate Assistance Program as published from time to time in the Pennsylvania Bulletin pursuant to Section 1 of Act 7 of 2023.-

~~2.3~~4 If a homestead is owned and occupied for only a portion of a year or is owned in part by a person who does not meet the qualifications for a claimant, exclusive of any interest owned by a claimant's spouse, or if the claimant is a widow or widower who remarries, or if the claimant is a permanently disabled person who is no longer disabled, the real property taxes shall

be apportioned in accordance with the period or degree of ownership or eligibility of the claimant in determining the amount of rebate for which a claimant is eligible.

### Section 3

#### Filing of Claim

3.1 A claim for property tax rebate shall be filed with the Chief Financial Officer of the East Stroudsburg Area School District between the first day of July and the thirty-first day of ~~October~~ **December** of the year next succeeding the end of the calendar year in which the real property taxes were levied, due and payable. Only one (1) claimant from a homestead each year shall be entitled to property tax rebate. If two (2) or more persons are able to meet the qualifications for a claimant, they may determine who the claimant shall be. If they are unable to agree, the Chief Financial Officer of the East Stroudsburg Area School District shall determine to whom a rebate is to be paid.

### Section 4

#### Proof of Claim

4.1 Each claim shall include reasonable proof of household income in the form of both state and federal income tax returns and relevant schedules and addenda for the applicable year as filed, a copy of the Claimant's SSA-1099, ~~an executed IRS Form 4506-T~~, a paid tax receipt evidencing that the real property taxes on the homestead have been paid, a complete **signed** copy



of the Claimant's PA-1000 Property Tax Rebate form, evidence of receipt of the state rebate. If the claimant is a widow, or widower, a copy of the declaration of such status in such manner as may be prescribed by the Secretary of Revenue of the Commonwealth of Pennsylvania pursuant to the Pennsylvania Senior Citizens Property Tax and Rent Rebate and Assistance Act shall be included. Proof that a claimant is eligible to receive disability benefits under the Federal Social Security Act shall constitute proof of disability under this Resolution. No person who has been found not to be disabled by the Social Security Administration shall be granted a rebate under this Resolution. A claimant not covered under the Federal Social Security Act shall be examined by a physician designated by the District at the expense of the claimant and such status determined using the same standards used by the Social Security Administration. It shall not be necessary that such taxes were paid by the claimant himself/herself; provided, that the taxes must have been paid not later than December 31 of the calendar year during which the real property taxes were levied, due and payable. The first claim filed shall include proof that the claimant or his spouse was age sixty-five (65) or over, or fifty (50) years or over in the case of a widow, or widower, during the calendar year in which the real property taxes were levied, due and payable. All of the aforementioned documentation must demonstrate that the Claimant is resident at the Claimant's Homestead, and any documentation reflecting residence other than the Homestead shall be grounds for denial of the claim.

## Section 5

### Determination of Claim

5.1 The Chief Financial Officer of the East Stroudsburg Area School District, or his designee, shall review each submitted claim and render a determination as to the Claimant's

entitlement to a rebate under this Resolution, all of the defined terms contained herein, and all of the claim submission requirements contained herein.

## Section 6

### Claim Forms

6.1 Claims shall be filed only on forms prepared and provided by the East Stroudsburg Area School District.

## Section 7

### Fraudulent Claim:

#### Conveyance to Obtain Benefits

7.1 In any case in which a claim is excessive and was filed with fraudulent intent, the claim shall be disallowed in full and a penalty of twenty-five (25%) percent of the amount claimed shall be imposed. The penalty and the amount of the disallowed claim, if the claim had been paid, shall bear interest at the rate of one and one-half percent (1.5%) per month from the date of the claim until repaid. The claimant and any person who assisted in the preparation or filing of a fraudulent claim shall be guilty of a misdemeanor, and, upon conviction thereof, shall be sentenced to pay a fine not exceeding One Thousand (\$1,000.00) Dollars, or to imprisonment not exceeding one (1) year, or both.

7.2 A claim shall be disallowed if the claimant received title to the homestead primarily for the purpose of receiving property tax rebate.

## Section 8

### Petition for Redetermination

8.1 Any claimant whose claim for property tax rebate is either denied, corrected or otherwise adversely affected by the Chief Financial Officer of the East Stroudsburg Area School District, or his designee, may file with the Board of Education a petition for redetermination within ninety (90) days after the date of mailing or written notice by the Chief Financial Officer of such action. Such petition shall set forth the grounds upon which claimant alleges that such action of the Chief Financial Officer is erroneous or unlawful, in whole or in part, and shall be accompanied by an affidavit or affirmation that the facts contained therein are true and correct. The Board of Education shall hold such hearings as may be necessary for the purpose of redetermination, and each claimant who has duly filed such petition for redetermination shall be notified by the Board of Education of the time when, and the place where, such hearing in his or her case will be held.

## Section 9

### Severability

9.1 The provisions of this Resolution are severable; if any word, phrase, clause, sentence, section or provision of this Resolution is for any reason held to be unconstitutional or illegal or invalid, the decision of any Court shall not affect or impair any of the remaining provisions of this Resolution. It is hereby declared to be the intent of the Board of Education of the East Stroudsburg Area School District that this Resolution would have been adopted had such unconstitutional or illegal or invalid word, phrase, clause, sentence, section or provision thereof not been included herein.

Section 10

Effective Date and Continued Effect

10.1 This Resolution shall be effective for the 2023 tax year. This Resolution and the provisions hereof shall continue in full force and effect from year to year until and unless the same are rescinded, revoked or amended by formal action of the Board of Education.

**DULY ADOPTED**, by the Board of Education of the East Stroudsburg Area School District, in lawful session duly assembled, this ~~16th day of March, 2020~~<sup>23<sup>rd</sup></sup> day of October, 2023.

EAST STROUDSBURG AREA SCHOOL DISTRICT

By: \_\_\_\_\_  
President of the Board of Education

ATTEST:

\_\_\_\_\_  
Secretary of the Board of Education

(SEAL)



# Expansion to Property Tax/Rent Rebate Program – Changes Coming in 2024

Governor Josh Shapiro delivered on a promise he made to older Pennsylvanians when he signed a new law, Act 7 of 2023, that significantly expands the Property Tax/Rent Rebate (PTRR) program. This historic legislation delivers the largest targeted tax cut for Pennsylvania seniors in nearly two decades.

Under the expansion first proposed by the Governor, nearly 175,000 more Pennsylvanians will qualify for a property tax or rent rebate. At the same time, many of the 430,000 claimants who previously qualified under the program's prior guidelines will see their rebates increase.

## What's New?

Starting in mid-January 2024, the Department of Revenue will open the filing period for eligible applicants to submit applications for rebates on property taxes and rent paid in 2023.

Here are the changes that will take effect at that time:

**First**, the maximum standard rebate is increasing from \$650 to \$1,000.

**Second**, the income cap for both renters and homeowners will be made equal and increase to \$45,000 a year:

- The income cap for homeowners will increase from \$35,000 to \$45,000
- The income cap for renters will increase from \$15,000 to \$45,000

**Third**, the income caps will be tied to the cost-of-living moving forward, meaning those who receive a rebate won't lose their eligibility in the future due to no fault of their own.

# ELIGIBILITY TABLE FOR HOMEOWNERS AND RENTERS

INCOME	MAX REBATE
\$0 - \$8000	\$1,000
\$8,001 - \$15,000	\$770
\$15,001 - \$18,000	\$460
\$18,001 - \$45,000	\$380

## Supplemental Rebates

The income eligibility did not change for supplemental rebates under the new law. However, the amounts were increased based on the new standard rebate levels. Supplemental rebates are still automatically calculated for property owners with \$30,000 or less in income who live in:

- Philadelphia, Scranton, or Pittsburgh.
- Property taxes are 15% or more of total income.

Income	Standard Rebate	Supplement (Kicker)	Total Max Rebate
\$0-\$8,000	\$1,000	\$500	\$1,500
\$8,001-\$15,000	\$770	\$385	\$1,155
\$15,001-\$18,000	\$460	\$230	\$690
\$18,001-\$30,000	\$380	\$190	\$570

## What Has Stayed the Same?

- **Forms and Schedules:** There are no changes to the forms or schedules used for filing a rebate application, meaning prior applicants will use the same process to file their applications that they are accustomed to.
- **Eligibility Criteria:** Applicants of the Property Tax/Rent Rebate program must still fall under one of the previous four categories to qualify. That means the program will continue to benefit eligible Pennsylvanians age 65 and older; widows and widowers age 50 and older; and people with disabilities age 18 and older.

# Important Dates in 2024

Although the income caps and the maximum standard rebate have increased, the key dates that applicants should be aware of have stayed the same under the new law.

## January:

- The Department of Revenue opens the online application on [myPATH<sup>ov</sup>](https://myPATH.pa.gov/) (<https://myPATH.pa.gov/>) to allow eligible applicants to file their rebate applications on property taxes or rent paid in 2023.
- Property Tax/Rent Rebate program booklets will be mailed to applicants who filed a paper rebate application for the prior application year.
- Forms and instructions for the 2023 application year are uploaded to the Department of Revenue website.

## April:

- Posting/processing begins.
- Automated calls begin to notify applicants that their applications were received.

## June:

- Automated calls begin to notify applicants that their applications were approved.
- The Department of Revenue evaluates the program prior to the statutory June 30th filing deadline to determine if funds are available to extend the deadline.

## July:

- **July 1:** This is the first day that rebates will be paid via direct deposit and checks will be mailed to applicants.

## December:

- **December 31:** It is expected this will be the final filing deadline for rebate applications on property taxes or rent paid in 2023.

# How to File

All eligible Pennsylvanians are encouraged to file their rebate applications online using

[myPATH](https://myPATH.pa.gov) (<https://myPATH.pa.gov>) or [myPATH](https://myPATH.pa.gov) (<https://myPATH.pa.gov>). Click on the "Apply for a Property Tax/Rent Rebate" hyperlink from the "Rebates" panel on the homepage.

[myPATH](https://myPATH.pa.gov) (<https://myPATH.pa.gov>) is the fastest, easiest, and most secure way for eligible applicants to submit their applications.

## Prior applicants:

- Any person who filed a Property Tax/Rent Rebate application **by paper** will automatically receive a PTRR Booklet in the mail from Department of Revenue.
- Any person who filed **via [myPATH](https://myPATH.pa.gov)** (<https://myPATH.pa.gov>) **or went to a tax preparer** will automatically receive a reminder letter and rent certificate in the mail from Department of Revenue.

## V. ITEMS FOR DISCUSSION

- d. Discovery Education (CIU20) - Renewal - \$5,130.13 paid by C&I



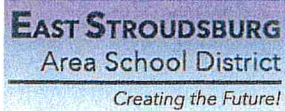

William Vitulli <william-vitulli@esasd.net>

### Form 611

1 message

Google Forms <forms-receipts-noreply@google.com>

Fri, Sep 22, 2023 at 1:38 PM

To: william-vitulli@esasd.net

Thanks for filling out

Form 611

Here's what was received.

Edit response

## Form 611

MUST BE COMPLETED FOR ANY PROCUREMENT OF A SERVICE OR ITEM OVER \$5,000.00

Your email ([william-vitulli@esasd.net](mailto:william-vitulli@esasd.net)) was recorded when you submitted this form.

Untitled Section

FORM 611

EAST STROUDSBURG AREA SCHOOL DISTRICT  
Procurement Form

Name of Requestor \*

Vitulli

Department \*

C&I

---

Building \*

Admin

---

**What service or item are requesting \***

Discovery Education via CIU20

---

**Why are you requesting the service or item \***

Renewal - Video source

---

**Suggested replacement \***

None at this time

---

Please complete an independent Cost Analysis. (Pre-determine costs prior to contacting a vendor.)

n/a

---

Cost Estimate: if over \$5,000, were three (3) quotes obtained? If yes, please list the vendor's information and quoted amount. \*

No

---

**What is the total cost of the purchase? \***

\$5,130.13

Procurement Method: \*

Quote Received only one Proposal

Request for Proposal (RFP)

Bid

Other: .....

Was this purchase budgeted? \*

Yes ▼

Was this purchased through a PA State Contract or Approved Consortiums? If yes, select group.

Yes

Pennsylvania State Contract

COSTARS

Keystone Purchasing Network

PEPPM National Contract Program (Technology Bidding and Purchasing)

US Communities

No

If item was purchased through a Pa State Contract or approved Consortium, please include contract number.



n/a

Which Fund will be charged? \*

10



What account will be charged? \*

10-1110-640-000-30-000-004-000-0000

Selection of the winning proposal, was the lowest price selected? If not, please explain why and the process of selecting the vendor. \*

single provider

Any additional information you would like to provide.

[Create your own Google Form](#)

[Report Abuse](#)

---

CONFIDENTIALITY NOTICE: This email message, including any attachments, is for the sole use of the intended recipient(s) and contains confidential and privileged information. Any unauthorized review, use, disclosure or distribution is prohibited. If you are not the intended recipient, please contact the sender by reply email, and destroy all copies of the original message.



6 Danforth Drive  
Easton PA 18045-7899  
p: 610-252-5550  
f: 610-252-5740  
www.ciu20.org

Aug 22, 2023

Renewal of Discovery Education Services (DEX) for 2023-24 School Year

East Stroudsburg Area SD  
William Vitulli  
[william-vitulli@esasd.net](mailto:william-vitulli@esasd.net)  
50 Vine Street  
East Stroudsburg, PA 18301  
570-424-8060

	\$1.65 per student
Discovery Education Experience (DEX)	\$550.00 minimum per building

\*Cost Per Student \$.825

- HSN: 932
- HSS: 1304
- LEH: 575
- JTL: 904
- BES: 391
- RES: 392
- MSE: 377
- ESE: 574
- JMH: 436
- SME: 296

Minimum: \$550.00 per building: 1 building @ \$550.00 /  
5,885 @\$1.65 = \$9,710.25

Total Cost \$10,260.25

Total Billed to East Stroudsburg School District: \$5,130.125

## V. ITEMS FOR DISCUSSION

e. HiTech Instruments - 30 microscopes - \$16,465.00 paid by ESSERs

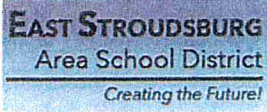

William Vitulli <william-vitulli@esasd.net>

### Form 611

1 message

Google Forms <forms-receipts-noreply@google.com>  
To: william-vitulli@esasd.net

Wed, Oct 4, 2023 at 10:23 AM

Thanks for filling out

Form 611

Here's what was received.

[Edit response](#)

## Form 611

MUST BE COMPLETED FOR ANY PROCUREMENT OF A SERVICE OR ITEM OVER \$5,000.00

Your email ([william-vitulli@esasd.net](mailto:william-vitulli@esasd.net)) was recorded when you submitted this form.

Untitled Section

**FORM 611**

**EAST STROUDSBURG AREA SCHOOL DISTRICT**  
Procurement Form

Name of Requestor \*

Vitulli

Department \*

C&I

Building \*

High Schools

**What service or item are requesting \***

30 microscopes

---

**Why are you requesting the service or item \***

replace old scopes

**Suggested replacement \***

EXC-100 Binocular

Please complete an independent Cost Analysis. (Pre-determine costs prior to contacting a vendor.)

n/a

Cost Estimate: if over \$5,000, were three (3) quotes obtained? If yes, please list the vendor's information and quoted amount. \*

HBAR SCi - \$599 each / Micro solutions \$16,200 (no setup)/ AM Scope \$599 each/ HiTech Instruments \$535.50 each with setup

**What is the total cost of the purchase? \***

\$16,465

Procurement Method: \*

- Quote Received only one Proposal
- Request for Proposal (RFP)
- Bid
- Other: online search / quotes

---

Was this purchase budgeted? \*

Yes ▼

Was this purchased through a PA State Contract or Approved Consortiums? If yes, select group.

- Yes
- Pennsylvania State Contract
- COSTARS
- Keystone Purchasing Network
- PEPPM National Contract Program (Technology Bidding and Purchasing)
- US Communities
- No

If item was purchased through a Pa State Contract or approved Consortium, please include contract number.

n/a

Which Fund will be charged? \*

10

What account will be charged? \*

ESSERs III

---

Selection of the winning proposal, was the lowest price selected? If not, please explain why and the process of selecting the vendor. \*

setup is provided by a local vendor / 2nd purchase from same vendor who will service in future

Any additional information you would like to provide.

[Create your own Google Form](#)

[Report Abuse](#)

---

CONFIDENTIALITY NOTICE: This email message, including any attachments, is for the sole use of the intended recipient(s) and contains confidential and privileged information. Any unauthorized review, use, disclosure or distribution is prohibited. If you are not the intended recipient, please contact the sender by reply email, and destroy all copies of the original message.





## Quotation

Quote Date: 10/02/2023

Quote No.: 48496

Customer No.: 03008

Salesperson: Mike Hartzell Service

Quote To: East Stroudsburg Area School District  
 Business Office Attn: A/P  
 50 Vine Street  
 East Stroudsburg, PA 18301

Ship To: East Stroudsburg Area School District  
 High School South  
 279 N. Courtland St.  
 East Stroudsburg, PA 18301

Ship Via	F.O.B.	Terms		
BEST WAY	Origin	Net 30		
Item Number	Description	Quantity	Unit Price	Amount
HT-EXC-100	EXC-100 Binocular Microscope	30	595.00	17850.00

- LED illumination
- Coaxial focus assembly
- 10X 18 eyepieces, one with pointer
- 4X, 10X, 40X, 100X Oil Achromat objectives
- Condenser with aperture
- Rackless mechanical stage w/scale
- Carrying handle
- Rechargeable AA 1300mAh Batteries

Includes setup

Discount 10% -1785.00

Delivery via ABF Freight

Quotation valid for 30 days from issue date

Credit card payments in excess of \$1000 are subject to 3.5% transaction fee.

QUOTE SUBTOTAL:	16065.00
FREIGHT CHARGES:	400.00
<b>QUOTE TOTAL:</b>	<b>16465.00</b>

Signature: Mike Hartzell Service

**Hitech Instruments, Inc.**  
 925 Main Street, Suite 200  
 Pennsburg, PA 18073

[www.hitechinstruments.com](http://www.hitechinstruments.com)

Phone: (215)-679-3929  
 Fax: (215)-679-3629  
 Email: [sales@hitechinstruments.com](mailto:sales@hitechinstruments.com)





**ACCU-SCOPE®**

MICROSCOPY & IMAGING SOLUTIONS

**EXC-100 Series**  
Student Microscopes

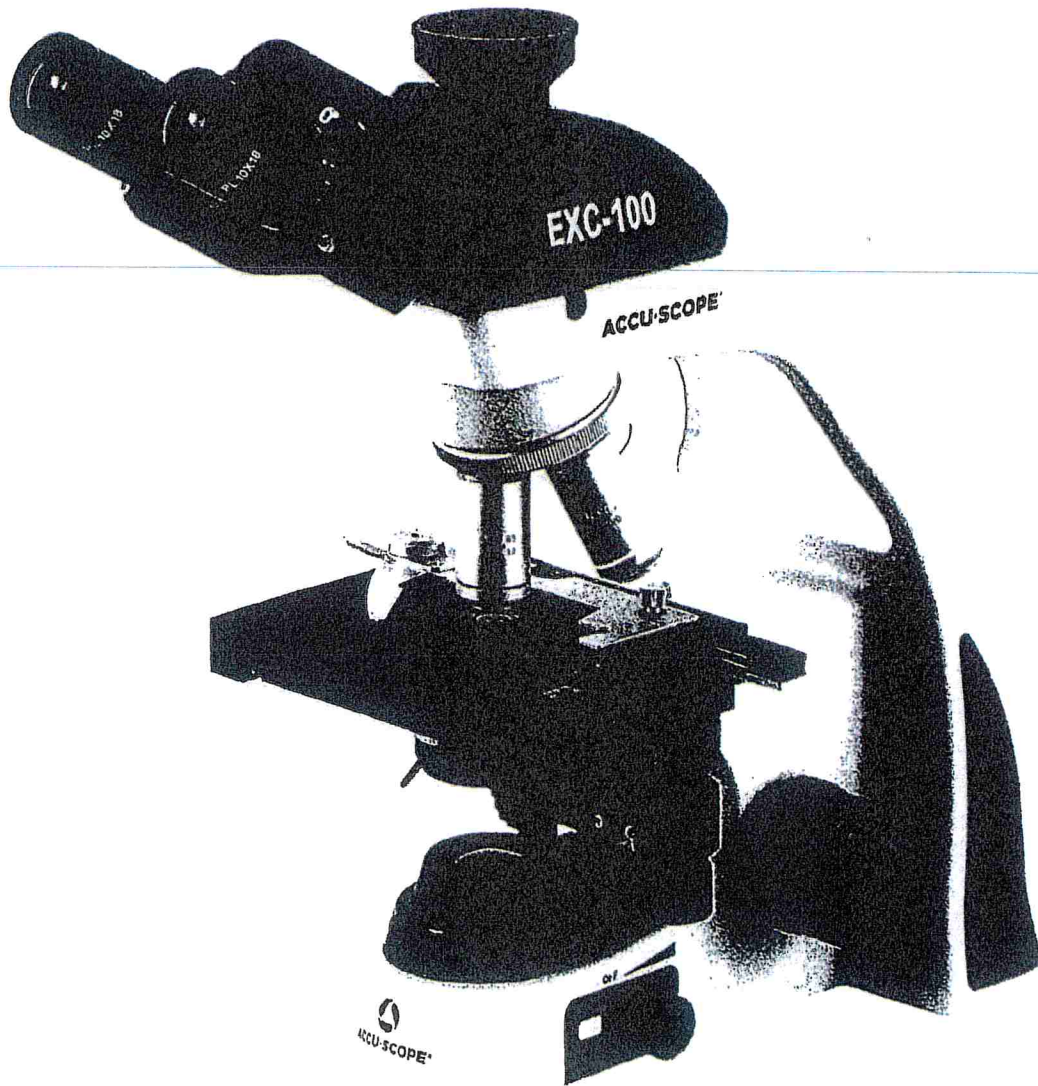

EXC-103 trinocular  
microscope

***Empowering Discovery. Advancing Results.***

# EXC-100 Student Microscopes

## SPECIFICATIONS

Viewing Head	<b>EXC-100:</b> Binocular, inclined 30°, rotatable 360°, adjustable interpupillary distance 50-75mm, right diopter adjustment; <b>EXC-103:</b> Trinocular, inclined 30°, rotatable 360°, fixed 50/50 light split (eyepieces/photo port), adjustable interpupillary distance 50-75mm, right diopter adjustment
Optical System	DIN Optical System, f = 160mm
Objectives	DIN Achromat 4x, 10x, 40xR* and 100xR* oil objectives (* spring loaded)
Eyepiece	WF10x eyepiece, 18mm field of view, pointer in one eyepiece
Nosepiece	Rear-facing, 4-position nosepiece with positive click stops to ensure objective alignment
Focusing System	Coaxial coarse and fine focus, focus tension adjustment; focus travel stop
Stage	Double-layer mechanical stage, right side XY controllers, 115x125mm, slide holder
Condenser	N.A. 1.25 condenser, iris diaphragm, filter holder
Illumination	Variable and rechargeable* 0.2W LED Illuminator (*requires three AA 1300mAh 1.2V NiMH batteries, included)
Stand	Cast aluminum alloy with built-in carry handle and power cord wrap
Power	Universal power supply (built-in); Input 100-240VAC, output 5V 1A
Accessories	Instruction manual
Camera Adapters (EXC-103 only)	Optional: 0.35x, 0.5x, 0.65x and 1.0x C-mount camera adapters; Photo tube (requires camera adapter, not included)
Warranty	5-year limited warranty for parts, labor and electronic components; 1-year warranty on LED bulb

## EXC-100 Series Dimensional Drawings

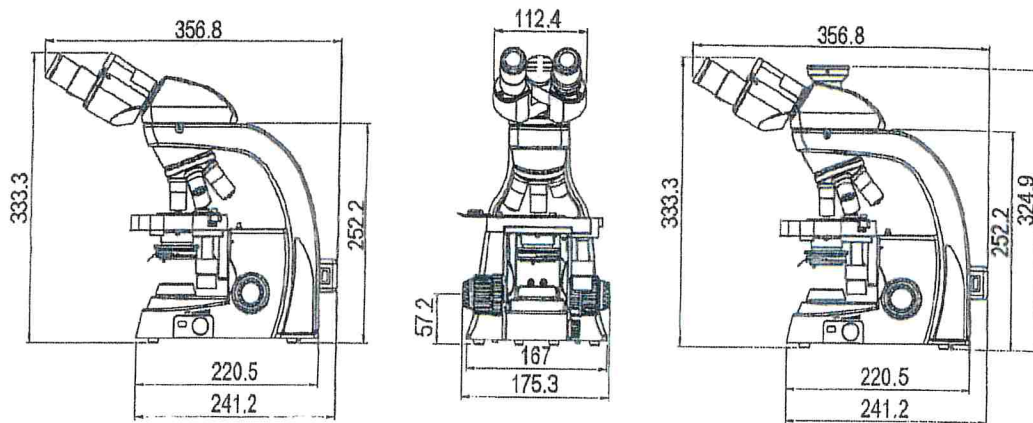

Dimensions in mm



Copyright © 2023 ACCU-SCOPE Inc. All rights reserved. Printed in the U.S.A. ACCU-SCOPE Inc. reserves the right to change and improve specifications without notice due to technological or manufacturing advances.



v031523

www.accu-scope.com • info@accu-scope.com • 631-864-1000 • 73 Mall Drive, Commack, NY 11725

Delivering to East Str... 18301  
Choose location for most accurate options

Electronics \* Search Amazon

- Home
- Electronics
- Camera & Photo
- Deals
- Best Sellers
- DSLR Cameras
- Mirrorless Cameras
- Lenses
- Point-and-Shoots
- Sports & Action Cameras
- Camcorders
- Binoculars
- Telescopes
- Microscopes
- Binoculars
- Microscopes
- Compound Binocular Microscopes

### AmScope AmScope - SM-4MTP 7X-45X Simul-Focal Stereo Lockable Zoom Microscope on Dual Arm Boom Stand

Electronics > Camera & Photo > Binoculars & Scopes > Microscopes > Compound Microscopes > Compound Binocular Microscopes

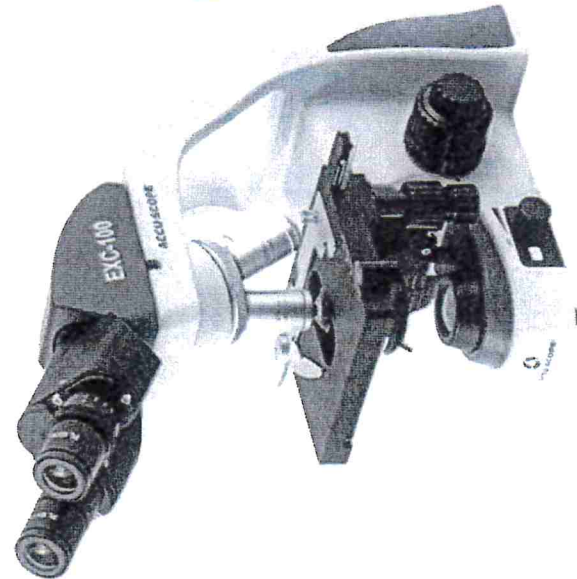

Roll over image to zoom in

## Accu-Scope Compound Microscope EXC-1 Head, 40-1000X Magnification, Mechanic Achromat Objectives, Cordless LED Illumi

Visit the Accuscope Store

Search

\$599<sup>99</sup>

Pay \$50.00/month for 12 months, interest-free upon appr

Light Source Type	LED
Material	Metal
Item Dimensions LxWxH	10 x 7.8 x 14.5 inches
Real Angle of View	30 Degrees
Magnification Maximum	1000 x

See more

### About this item

- GREAT IMAGES** || Ideally suited for the classroom environment, the EXC-100 Microscope provides clear images during observation, with front lens surfaces that are flush and easy to clean. The achromat 4x, 10x, 40xR\*, and 100xR\* oil immersion DIN objectives provide 40X-1000X magnification. Variable LED control with Abbe condenser and iris diaphragm delivers bright, even illumination for excellent image contrast
- ERGONOMIC** || Features a binocular head with interpupillary adjustment and low positioned coaxial focusing mechanism for complete ergonomic comfort to users during extended viewing periods
- CORDLESS & PORTABLE** || With rechargeable LED illumination, built-in carry handle, and cord wrap, this microscope is highly portable, allowing you to take it wherever you need
- DURABLE CONSTRUCTION** || The rugged, die-cast aluminum frame with all metal gears and anti-mold optics is designed for years of use
- GREAT FOR HIGHER EDUCATION** || Engineered for classroom applications, the EXM-100 Microscope is a great choice for high schools and college students

### Add a Protection Plan:

- 2-Year Protection for \$49.99
- 3-Year Protection for \$64.99

Add to List

Have one to sell?  
Sell on Amazon





[Home](#)

[Service](#)

[Sales](#)

[About](#)

### My cart



Accu-Scope EXC-100 Series Student Microscope

\$16,200.00



\$540.00

Accu-Scope EXC-100 Series Microscope: Accu-Scope EXC-100 Binocular Stu...

- 30 +

[Enter a promo code](#)

[Add a note](#)

Subtotal

\$16,200.00

Delivery

FREE

Pennsylvania, United States

Total

\$16,200.00

[Secure Checkout](#)

Microscope Solutions, Inc., Holly Springs, NC | 800-231-7910

All Rights Reserved

Home / Educational Microscopes / Accu-Scope EXC-100 Series Student Microscope

< Prev Next >



## Accu-Scope EXC-100 Series Student Microscope

\$540.00

Accu-Scope EXC-100 Series Microscope

Select

Quantity

1

Add to Cart



*No set-up*



*M. microscope Solutions*

**Microscope EXC-100 - Binocular Head, 40-1000X Magnification, Achromat Objectives, Mechanical Stage, Iris Diaphragm, Cordless LED Illumination**

SKU ACCEXC100 by Accu-Scope

**Low Stock - 2 Remaining**

*Expected to Ship Today*

\$599.99

For volume discounts,  
Call (585) 360-2295 or

- +

[Get a Quote](#)

HBAR Sci  
\$599

VII. RECOMMENDATIONS BY THE PROPERTY/FACILITIES  
COMMITTEE

d. Current Project List





		\$	-		\$	-		\$	14,466.70

EHN Natatorium Roof Replacement Board Approved 1/24/2022 10-4600-450-990-30-819-463-000-8744 ESSER III Grant YR1 ESSERS PO#23001261 \$729,500.00 CR \$154,900.00 PO#24000000839		EHN Natatorium HVAC Replacement Project#287033 Board Approved 1/24/2022 10-4600-450-990-30-819-465-000-8744 ESSER III Grant YR1 PO#2400000844		SME Roof Project 2023 Proposal #5050562 Subcontractor: David Maines & Assoc. Board Approved 6/20/2022 32-4600-450-000-10-216-000-000-3060 PO# 2400000837	
7281	Munn Roofing Split between ESSER / CR	7288	ASL Mechanical \$277,290.00 Including Altermate#1 Replacement HX-5 \$183,700	3184	Tremco Commercial Sealants & Waterproof \$1,862,357.67
	\$ 884,400.00		\$ 460,990.00		\$ 1,862,357.67
	\$ 884,400.00		\$ 460,990.00		\$ 1,862,357.67
	\$ 105,986.70	6/14/2022	8,550.00	4/17/2023	\$ 24,944.06
	\$ 216,900.00	6/21/2022	\$ 5,580.00	9/22/2023	\$ 580,002.35
6/30/2023	\$ 147,228.30	6/30/2022	\$ 58,500.00	8/31/2023	\$ 580,002.35
7/31/2023	\$ 256,846.50	12/20/2022	\$ 106,200.00		
8/30/2023	\$ 28,300.00	8/30/2023	\$ 12,780.00		
		8/30/2023	\$ 9,000.00		
9/22/2023	\$ 96,570.00				
	\$ 851,831.50		\$ 200,610.00		\$ 1,184,948.76
	\$ 32,568.50		\$ 260,380.00		\$ 677,408.91
	96%		44%		64%
	A/C# 32-4400-450-000-30-819-463-000-0000		A/C# 32-4400-450-000-30-819-461-000-0000		
	Paid through Cap.Resv.		Paid through Cap.Resv.		
1/12/2022	\$ 15,319.50	1/19/2022	\$ 5,250.00		
1/19/2022	\$ 5,106.50	2/14/2022	\$ 14,107.80		
2/14/2022	16718.8	3/10/2022	\$ 1,111.82		
3/10/2022	\$ 3,095.40	4/21/2022	\$ 501.33		
4/21/2022	\$ 3,095.40	5/17/2022	\$ 3,226.30		
5/17/2022	\$ 6,190.80	6/8/2022	\$ 833.51		
6/8/2022	\$ 1,575.19	6/30/2022	\$ 2,747.39		
6/30/2022	\$ 1,328.42	9/22/2022	\$ 1,070.01		
6/30/2022	\$ 1,192.47				
10/24/2022	\$ 2,309.23				
11/8/2022	\$ 720.05				
2/21/2023	\$ 1,102.21				
4/4/2023	\$ 451.93				
6/26/2023	\$ 631.46				
7/28/2023	\$ 1,566.27				

Current Construction in Progress 7/27/2023

	\$	60,403.63		\$	28,848.16		\$	-



	\$	18,440.66				

Date	RES Elem HVAC Imporvements ESSER III 10-4600-450-990-10-215- 461-000-8744 \$1,500,000.00 ESSER ONLY Remaining out of Capital Reserve A/C#32-4600-450- 000-10-215-000-000-3051	Date	EHN Rooftop HVAC ESSER III 10-4600-450-990-30-819- 461-000-8744 \$3,539,010.00 ESSER ONLY ??? Remaining out of Capital Reserve A/C 32-4600-450-000-000-30- 819-000-000-3051	Date	EHS Flooring Replacment Board Approved 3/20/2023 32-4600-450-000-30-820- 000-000-3080
	Trane \$ 1,500,000.00		Trane \$ 3,539,010.00	6554	Cope Commercial Flooring \$ 1,224,395.00
	\$ 1,500,000.00		\$ 3,539,010.00		\$ 1,224,395.00
ACH Tranf	\$ 1,500,000.00	ACH Tranf	\$ 2,530,135.00		
	\$ -		\$ -	5/31/2023	\$ 433,595.70
				6/26/2023	\$ 283,535.10
				8/31/2023	\$ 73,972.80
				8/31/2023	\$ 249,020.10
				9/22/2023	\$ 14,194.44
	\$ 1,500,000.00		\$ 2,530,135.00		\$ 1,054,318.14
	\$ -		\$ 1,008,875.00		\$ 170,076.86
	100%		71%		86%
ACH Tranf/Trane	\$ 46,750.00			11/14/222	\$ 6,828.00
				12/31/2022	\$ 241.15
				12/31/2022	\$ 2,115.75
				2/27/2023	\$ 9,018.10
				4/4/2023	\$ 6,825.00
				4/21/2023	\$ 1,515.15
				6/26/2023	\$ 2,793.87
				6/26/2023	\$ 8,381.62
				9/22/2023	\$ 4,604.31



	\$	46,750.00		\$	-		





<p>EHN R-Newals (Chiller) A/C# 32-4600-450-000-20- 518-008-000-3096 Board Approved 8/21/2023</p>	<p>Total of Current Projects</p>	
<p>Trane</p>		
<p>\$ 194,977.50</p>	<p>\$ 13,763,173.67</p>	
	<p>\$ 20,040.00</p>	
	<p>\$ (3,367.00)</p>	
	<p>\$ -</p>	
<p>\$ 194,977.50</p>	<p>\$ -</p>	<p>\$ 13,779,846.67</p>
	<p>\$ 4,049,906.00</p>	
	<p>\$ 1,140,288.96</p>	
	<p>#REF!</p>	
	<p>\$ 1,626,701.92</p>	
	<p>\$ 1,197,400.60</p>	
	<p>\$ 864,373.88</p>	
	<p>\$ 293,148.00</p>	
	<p>#REF!</p>	
	<p>\$ 294,966.00</p>	
	<p>\$ 194,966.00</p>	
	<p>\$ -</p>	
	<p>\$ -</p>	
	<p>\$ -</p>	
	<p>\$ -</p>	
	<p>\$ -</p>	
	<p>\$ -</p>	
<p>\$ -</p>	<p>\$ 11,331,998.73</p>	<p>\$ 13,779,846.67</p>
	<p>\$ 2,447,847.94</p>	
<p>0%</p>	<p>82%</p>	
	<p>\$ 90,415.50</p>	
	<p>\$ 23,689.40</p>	
	<p>\$ 26,387.12</p>	
	<p>\$ 24,110.70</p>	
	<p>\$ 24,183.56</p>	
	<p>\$ 22,743.54</p>	
	<p>\$ 13,056.60</p>	
	<p>\$ 13,573.92</p>	
	<p>\$ 14,178.40</p>	
	<p>\$ 6,913.54</p>	
	<p>\$ 720.05</p>	
	<p>\$ 1,102.21</p>	
	<p>\$ 451.93</p>	
	<p>\$ 631.46</p>	
	<p>\$ 1,566.27</p>	
	<p>\$ -</p>	
	<p>\$ -</p>	
	<p>\$ -</p>	
	<p>\$ -</p>	
	<p>\$ -</p>	
	<p>\$ -</p>	

	\$	168,909.15	